



CAMPANAS INDUSTRIALES HASTA 100W LED HIGH BAY LIGHT UNTIL 100W



Campanas Industriales de 80 y 100W para la sustitución directa de las tradicionales campanas de mercurio alta presión o de sodio mejorando el rendimiento y obteniendo unos grandes ahorros energéticos. Montado con LEDs Philips Lumileds Luxeon y con driver de la marca Meanwell. Se ofrecen diferentes alternativas en temperatura de color y ángulos de iluminación.

High bay light 80 and 100w to be replaced the traditional high-pressure mercury or sodium lamps. Improved the energy efficiency and get energy saving. LED Philips Lumileds Luxeon assembled with Meanwell drivers. You can choose from several options like color temperature and light angle.

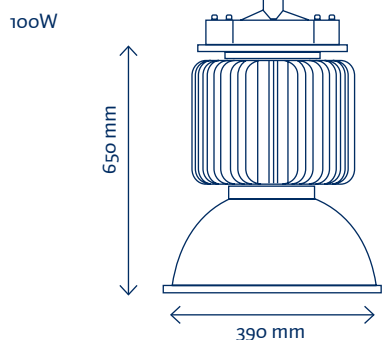
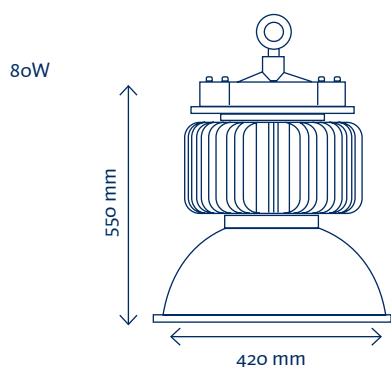

COMPARATIVA
COMPARATIVE
COB80w = 150W MH
COB100w = 200W MH

C-80W

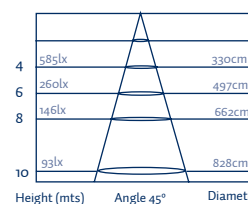
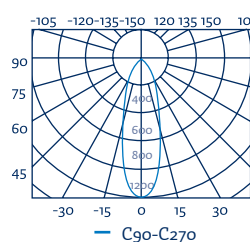

C-100W

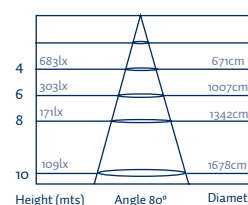
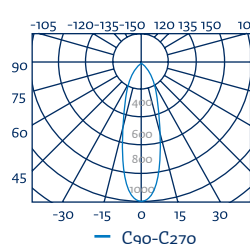

	TEMP. TEMP.	ÁNGULO ANGLE	ALIMENTACIÓN POWER SUPPLY	MEDIDAS MEASURE	TIPO DE LED LED TYPE	FLUJO LUM. LUM. FLOW	CONSUMO CONSUME
C-80W-XX-XX	4000° - 7000°	45°/80°/100°	90-260V AC	Ø420x550mm	Philips 80W	7000lm	95W
C-100W-XX-XX	4000° - 7000°	80°/100°	90-260V AC	Ø390x650mm	Philips 100W	9000lm	110W