

2.4GLEDRGBWController

Información técnica

V8 RF RGBW Control remoto

Remote Option:	RGBW, Control 4 zonas
Working Voltage :	3Vdc(BatteryCR2032)
Wireless Frequency:	2.4GHz
Working Temperature:	-30 -55
Package Size:	L150xW46xH18(mm) 85g
Weight(G.W.):	

R4-5A CV Receptor

Input Voltage:	5-24Vdc
Max Current Load:	5A x 4CH Max. 20A
Max Output Power:	100W/240W/480W(5V/12V/24V) -30 -55
Working Temperature:	150g
Package Size:	L178xW48xH33(mm)
Weight(G.W.):	

Note: Receiver is sold separately.

Dimensions

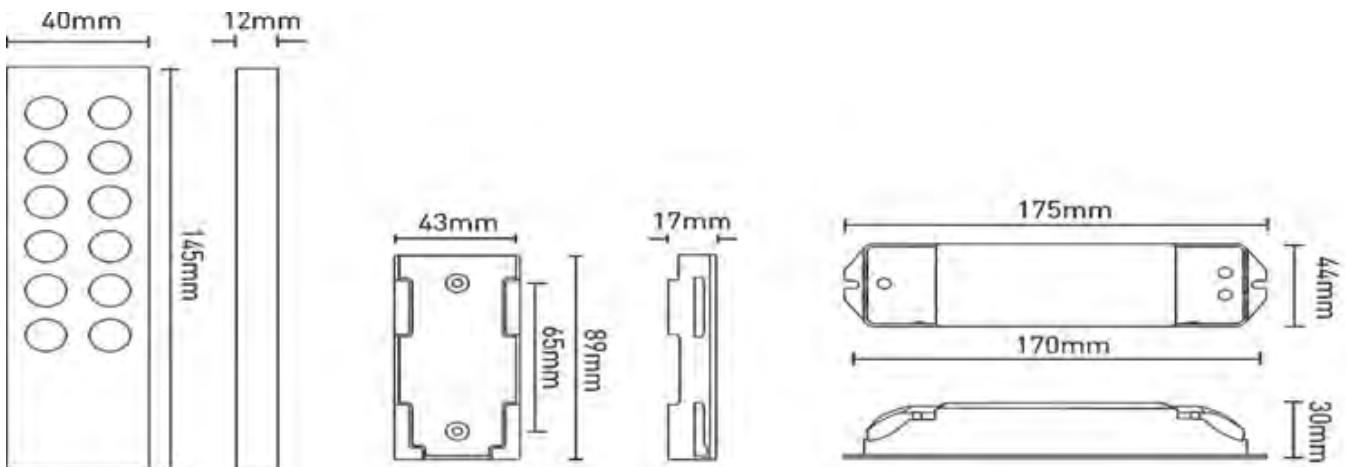

El control remoto V8 puede emparejarse con los paneles táctiles LTECH; comuníquese con el departamento de ventas para obtener los detalles de la operación.

Instrucciones del mando a distancia :

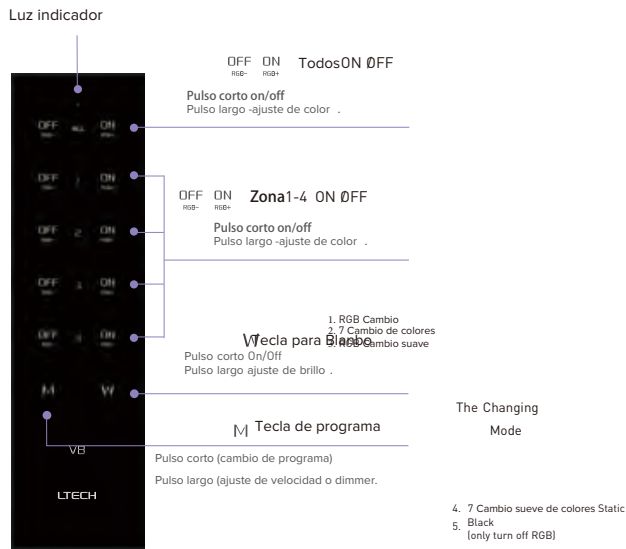

Emparejar / Borrar código entre controles remotos

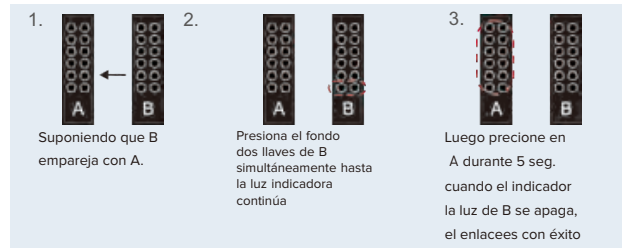

Borrar mando:

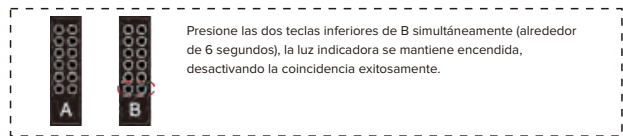

Match/Clear code between remote and receiver Match code:

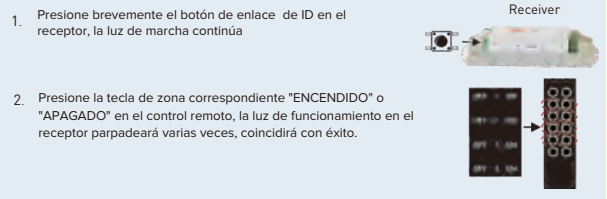

Limpiar receptor :

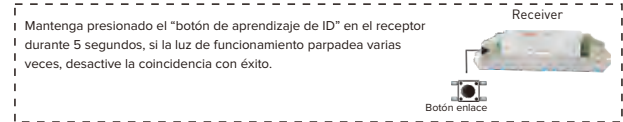

Instrucciones del receptor:

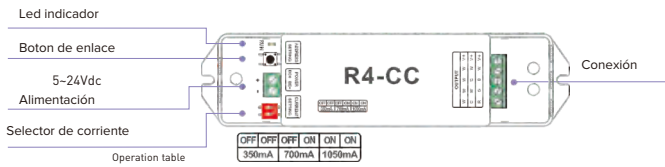

Wiring Diagram :

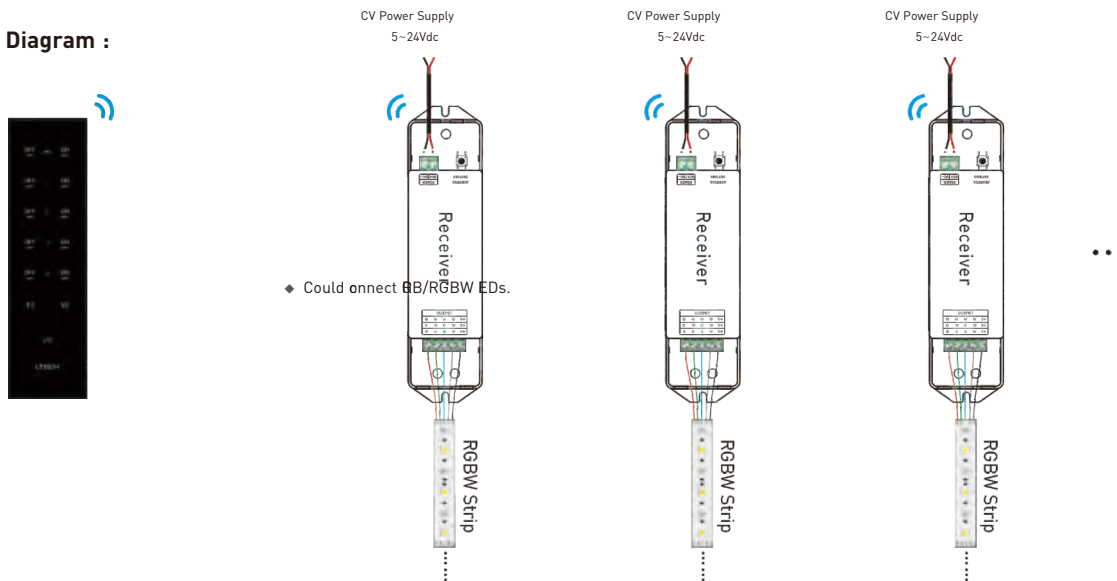

Atención:

- Reemplace la batería si el control remoto se vuelve insensible o si se acorta la distancia de control. Por favor, saque la batería durante mucho tiempo sin usar.